

exacontrol 7

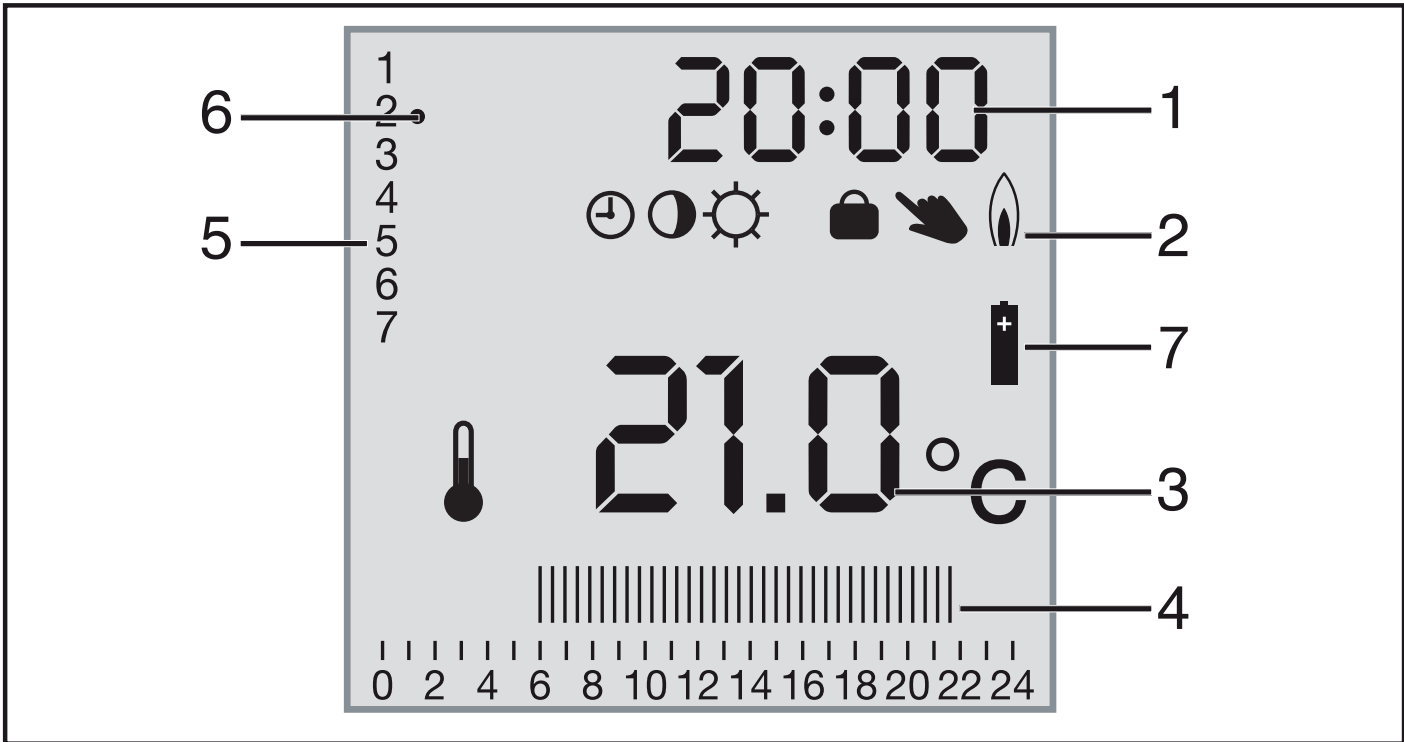





Saunier Duval









Utilisation

Laissez toujours tous les robinets des radiateurs complètement ouverts dans la pièce où se trouve votre thermostat d'ambiance.

Organes de commande

-  Sélectionner le mode de fonctionnement
- + Augmenter la valeur
- Réduire la valeur
- OK Confirmer la valeur, avancer dans le programme
- C Revenir en arrière/Restituer la valeur
-  Régler Choisir la température jour
-  Régler Choisir la température nocturne
- P Programmer les heures de chauffage
-  Régler les heures et jours de semaine

Vue d'ensemble de l'écran

- 1 Heure actuelle
- 2 Symboles
 -  La température ambiante est régulée par le programme sélectionné.
 -   - Période d'abaissement
 -   - Période de chauffe
 -  Régulation permanente de la température ambiante en fonction de la température d'abaissement.
 -  Régulation permanente de la température ambiante en fonction de la température jour

 Programme congés : la température ambiante est réglée en fonction de la température demandée pour la durée de vos vacances.

 Brève modification de température

 Demande chauffage à l'appareil

3 Temperature actuelle

4 Affichage barres (I = Période de chauffe)

5 Jour de la semaine (1 = lu., 2 = ma., 3 = me., 4 = je., 5 = ve., 6 = sa., 7 = di.)

6 Marquage du jour en cours de la semaine

7 Piles : clignotement = piles à changer, temps de fonctionnement restant: 4 semaines



Danger de surchauffe de la pièce: en cas de pile usée, la chaudière fonctionne avec une température maximale de départ (pour éviter le gel).

Description de l'appareil

Exacontrol 7 est un thermostat d'ambiance avec programmation hebdomadaire du chauffage.

Le thermostat dispose de 2 programmes de base P1 et P2, d'un programme bloc modifiable P3 et d'un programme individuel réglable Pi.

Réglage des programmes périodes de chauffe		Réglés d'usine
P1	6:00-22:00 heures	du lu au ve
P2	7:30-22:30 heures	sa
P3	réglable (pour plusieurs jours au choix)	di
Pi	réglable (pour chaque jour individuellement)	

Page

Choix du mode de fonctionnement81
Activer la fonction congés83
Brève modification de la température85
Réglage de la température jour87
Réglage de la température d'abaissement87
Réglage jour et heure89
Choix du programme de base91
Réglage des programmes P3 et Pi93
Remplacement Piles95
Enclenchement par téléphone97

Montage

Installation du thermostat d'ambiance

Cet appareil ne peut être ouvert et installé que par un professionnel qualifié conformément aux schémas des pages 98 à 100. Il convient, à cet effet de respecter les consignes de sécurité existantes.



Danger d'électrocution sur les raccords conducteurs de courant. Avant les travaux sur l'appareil, couper l'alimentation secteur et mettre des coupe-circuits avant la remise en marche.

Nous ne sommes pas responsables des dommages pouvant découler du non-respect de ce mode d'emploi, des câblages défectueux ou détériorations mécaniques.

Raccordement du commutateur téléphonique à distance

Le commutateur est raccordé sur les bornes TEL de la régulation (voir schéma page 100)

Merci de suivre la notice d'installation du commutateur téléphonique.

Type d'appareil	exacontrol 7
Tension de fonctionnement	2x1,5 V (AAA)
Durabilité	<400 μ A
Densité max. de charge	5 A/250 V~ $\cos \varphi = 1$
Réserve de marche	0,5 h
Durabilité des piles	1,5 années
Plage de température jour	5 ... 30°C
Temp. d'abaissement	5 ... 20°C
Différence de commutation	≤ 1 K
Câbles de raccordement	3x0,75 mm ²
Type de protection	IP 30
Classe de protection	III
Temp. de fonctionnement	+ 5 ... + 50 °C
Temp. stockage admise.	- 20 ... + 65 °C
Dimensions	120 x 85 x 32 mm
Entrée bornes TEL	230 V~ activée

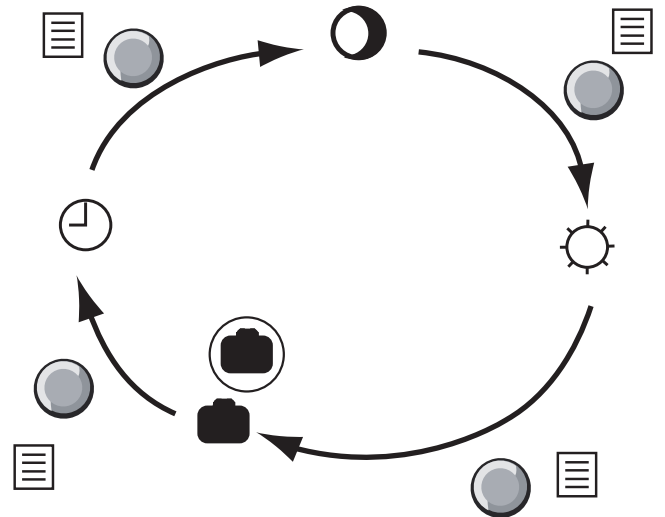
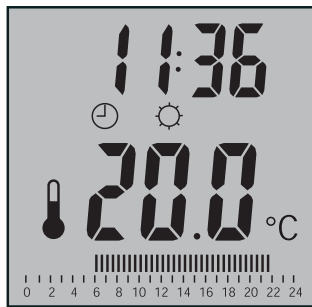
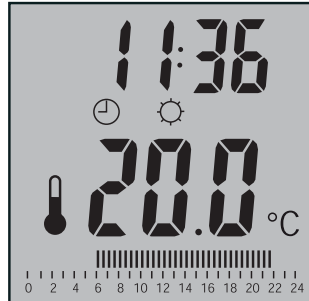

DE	Betriebsart wählen
GB	Choose the operating mode
FR	Choix du mode de fonctionnement
ES	Selección del Modo de Funcionamiento
PT	Selecção do Modo de Funcionamento
IT	Impostazione del il modo operativo
NL	Bedrijfsfunctie kiezen
DK	Valg af driftsart
PL	Wybór trybu pracy
HU	Üzem mód kiválasztása
CZ	Volba druhu provozu
RO	Selectarea regimului de funcționare
SK	Voľba prevádzkového režimu
TR	İşletme türü seçimi
RUS	Выбор режима работы

1

4x

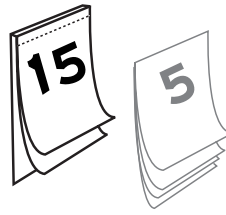
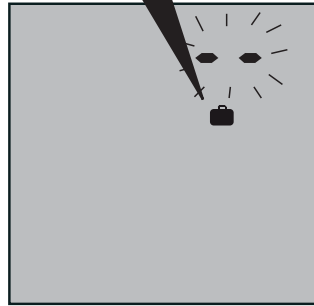
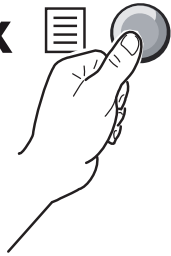

+

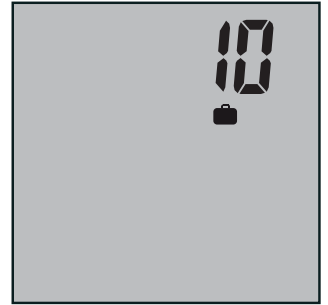

2

OK

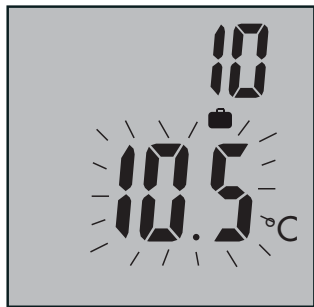

+

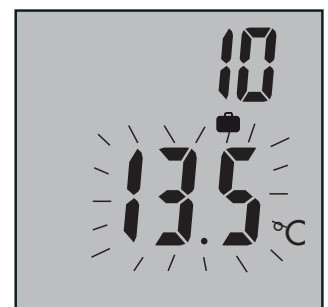

3

OK

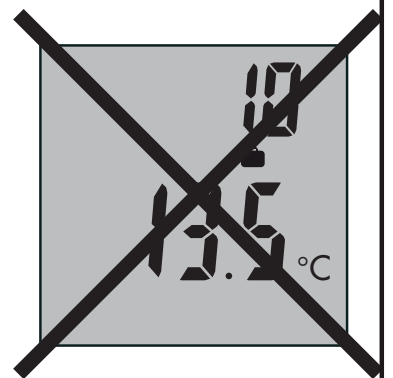
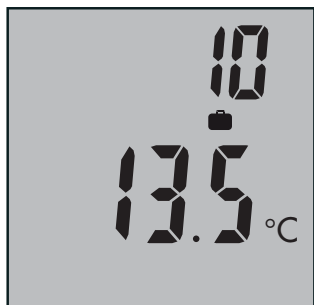

DE	Urlaubsfunktion aktivieren
GB	Activate the holiday program
FR	Activer la fonction congés
ES	Activación del Programa de Vacaciones
PT	Activação do Programa de Férias
IT	Impostazione programma vacanze
NL	Vakantieprogramma activeren
DK	Aktivering af feriedrift
PL	Aktywacja funkcji urlopowej
HU	Szabadság-funkciók aktiválása
CZ	Aktivace funkce "dovolená"
RO	Activarea funcției concediu
SK	Aktivácia dovolenkovej funkcie
TR	Tatil fonksiyonunu çalıştırma
RUS	Включение программы "Отпуск"

1

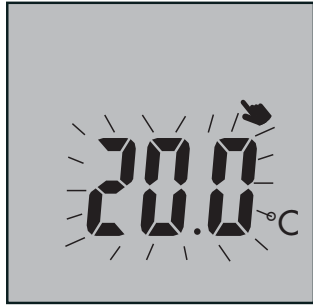

2a

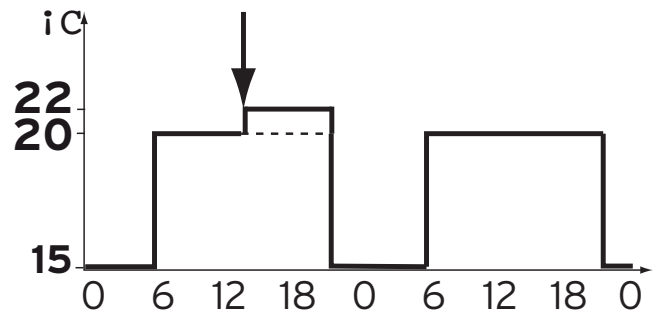
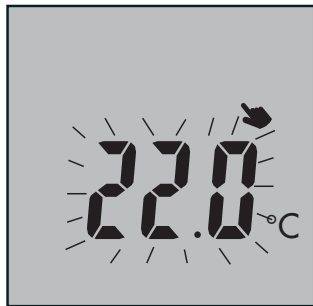

2b

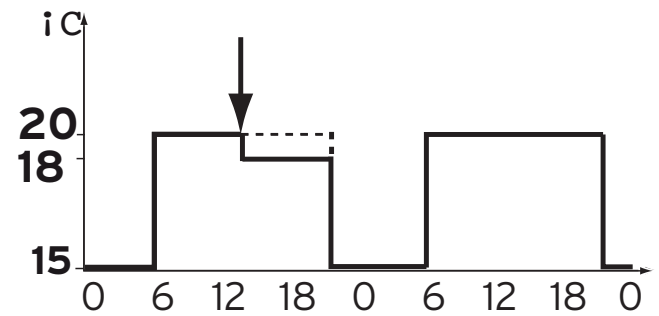
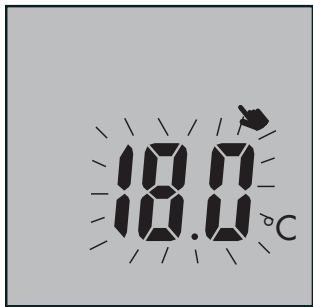
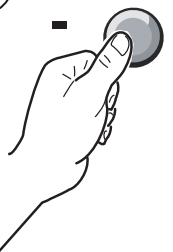

3

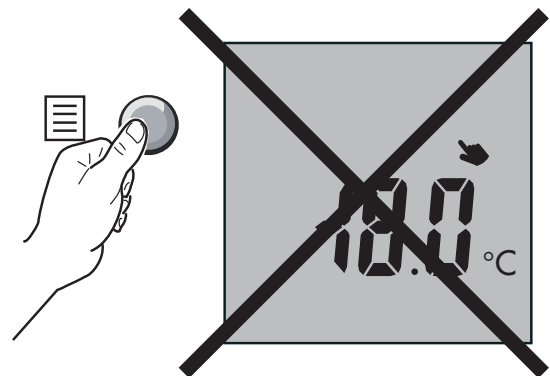
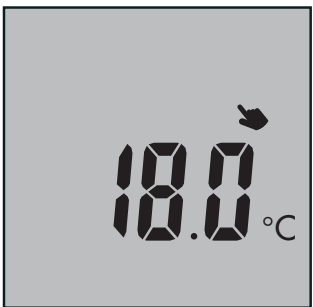

DE	Temperatur kurzfristig verstellen
GB	Temporary change of temperature setting
FR	Brève modification de la température
ES	Cambio de la temperatura a corto plazo
PT	Mudança breve de temperatura
IT	Modifica temporanea temp. ambiente
NL	Kamertemperatuur kortstondig wijzigen
DK	Midlertidig Índring af temperatur
PL	Krótkotrwałe przestawienie temperatury
HU	Hőmérséklet módosítása rövid időre
CZ	Krátkodobá změna teploty
RO	Scurtă modificare a temperaturii
SK	Krátkodobé prestavenie teploty
TR	Kısa süre için sıcaklık değıştirilmesi
RUS	Кратковременная перестановка температуры

☀ °C

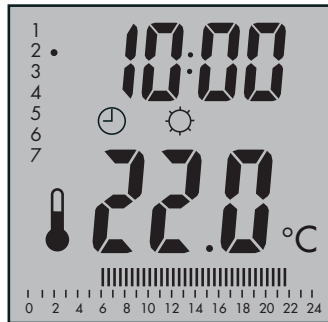
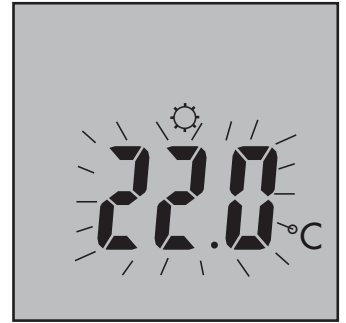
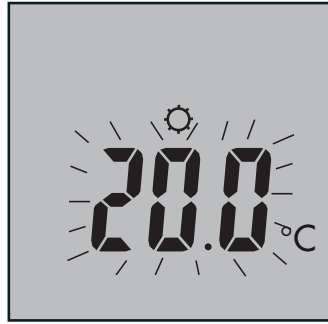

☾ °C

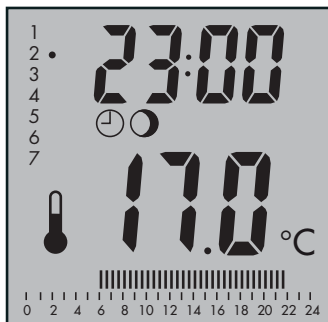
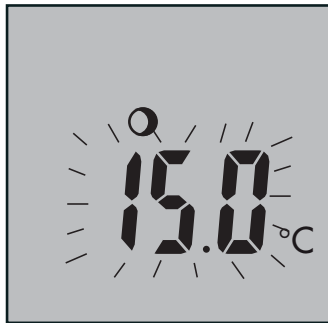

- DE** Tag-/Absenkttemperatur einstellen
- GB** Adjust the day / night temperature
- FR** Réglage température jour / d'abaissement
- ES** Selección de Temperatura Diurna / Selección de Temperatura Nocturna
- PT** Selecção de Temperatura Diurna / Selecção de Temperatura Nocturna
- IT** Impostazione della temperatura diurna / di abbassamento
- NL** Dagtemperatuur /
Verlagingstemperatuur instellen
- DK** Indstilling af dagtemperatur / nattemperatur
- PL** Ustawienie temperatury dziennej / obniżonej
- HU** Nappali hőmérséklet beállítása
Csökkentett hőmérséklet beállítása
- CZ** Nastavení denní / snížené teploty
- RO** Reglarea temperaturii de zi / de noapte
- SK** Nastavenie dennej / zníženej teploty
- TR** Gündüz konumu / Gece konumu
sicaklığının ayarlanması
- RUS** Установка дневной / ночной температуры
помещения

1



+

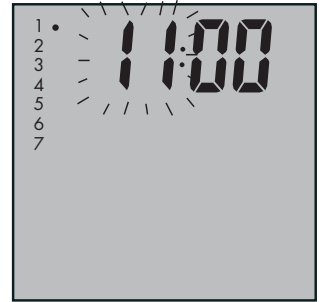

2

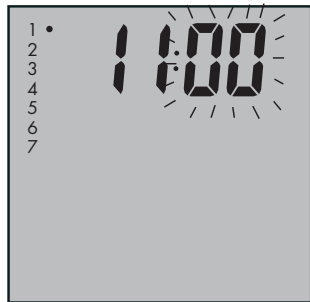

+

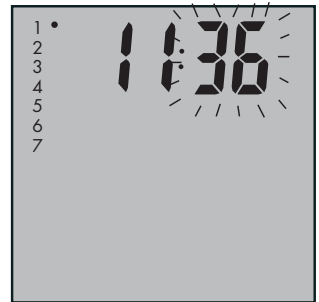

3



+

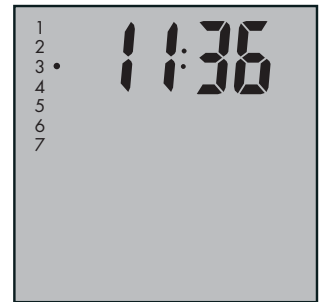

4

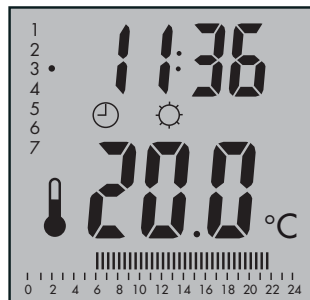

DE	Uhrzeit und Wochentag einstellen
GB	Set the date and time
FR	Réglage heure et jour
ES	Ajuste de la hora y del día de la semana
PT	Ajuste da hora e do dia da semana
IT	Impostazione ora e giorno della settimana
NL	Tijd en dag van de week instellen
DK	Indstilling af klokkeslét og ugedag
PL	Ustawienie godziny i dnia tygodnia
HU	A pontos idő és hét napjának beállítása
CZ	Nastavení denního času a dne v týdnu
RO	Reglarea orei și a zilei săptămânii
SK	Nastavenie dňa v týždni a času
TR	Aktüel saat ve günün ayarlanması
RUS	Установка времени времени и дня недели

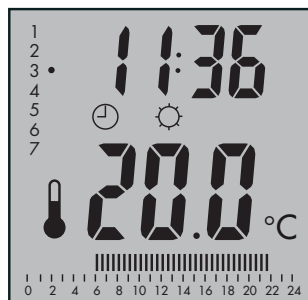
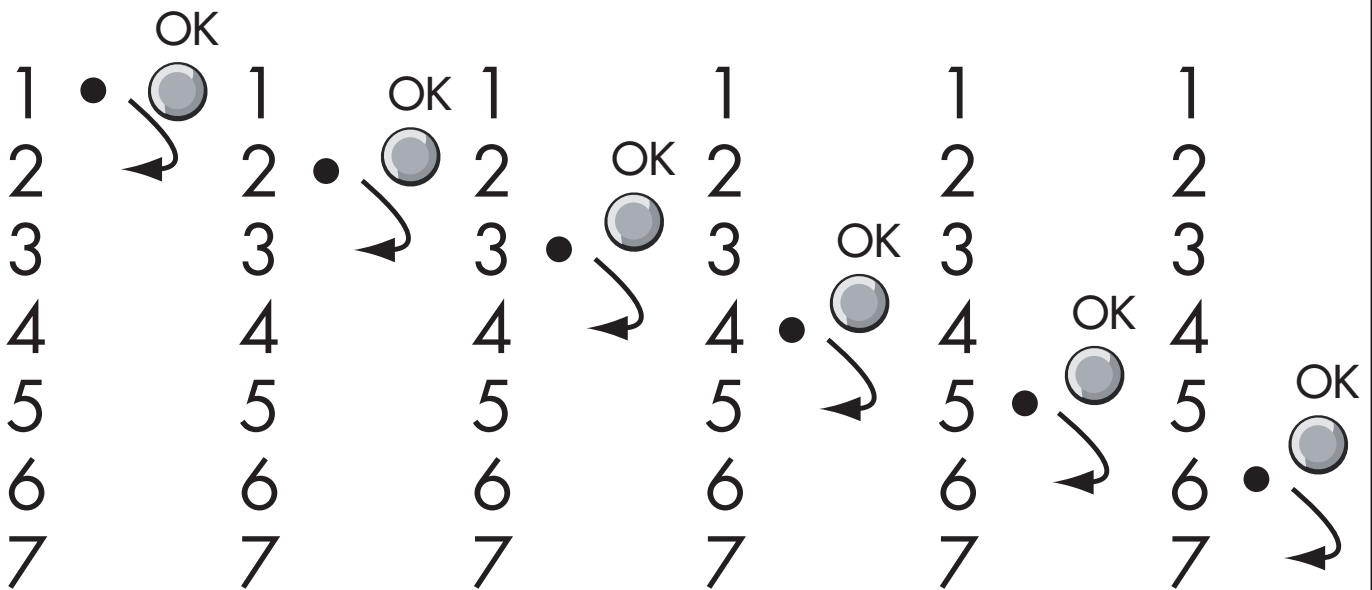
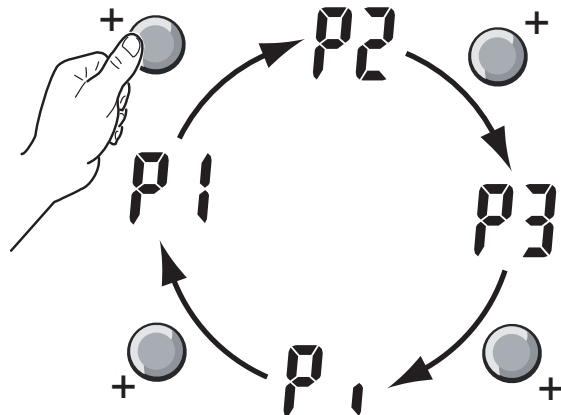
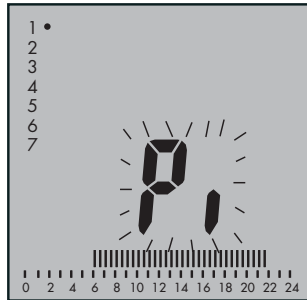
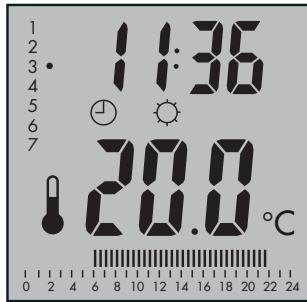

DE	Programm auswählen
GB	Choose a program
FR	Choix du programme
ES	Elección de programa
PT	Escolha do programa
IT	Scelta del programma
NL	Programma's kiezen
DK	Valg af program
PL	Wybór programu podstawowego
HU	Program kiválasztása
CZ	Výběr základního programu
RO	Selectarea programului de bază
SK	Výber základného programu
TR	Ana program seçimi
RUS	Выбор программы

1

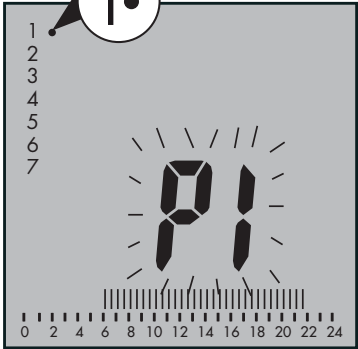

3x

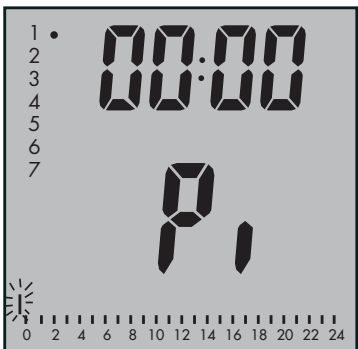
2



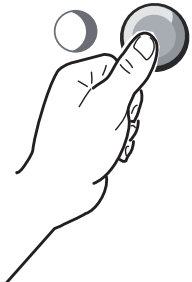
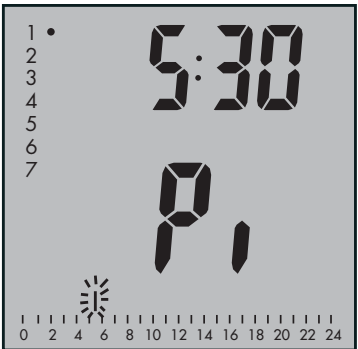

5:30 = 11x



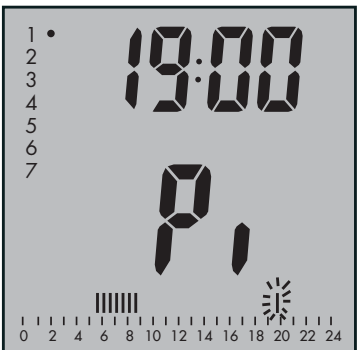

9:00 = 7x

3



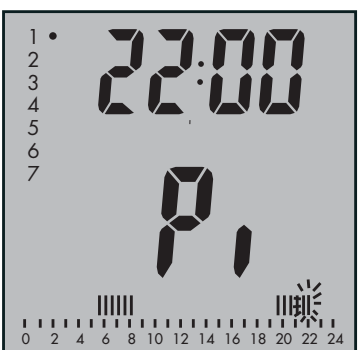

19:00 = 20x



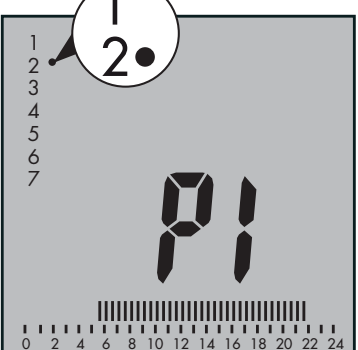

22:00 = 6x

4

DE	Programm P3 und Pi einstellen
GB	Set program P3 or Pi
FR	Réglage Programmes P3 et Pi
ES	Ajuste de los programas P3 y Pi
PT	Ajuste dos programas P3 e Pi
IT	Impostazione dei programmi P3 e Pi
NL	Programma's P3 en Pi instellen
DK	Indstilling af program P3 og Pi
PL	Ustawienie programów P3 i Pi
HU	P3 és Pi program beállítása
CZ	Nastavení programu P3 a Pi
RO	Modificarea programelor P3 și Pi
SK	Nastavenie programu P3 a Pi
TR	P3 ve Pi programlarının ayarlanması
RUS	Задание программ P3 и Pi

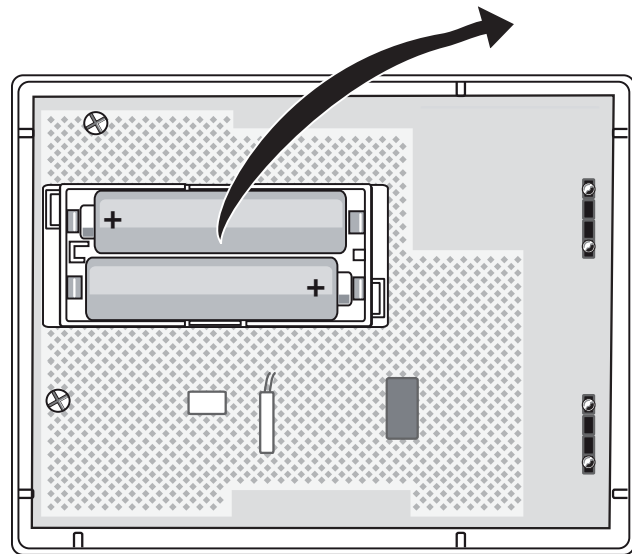
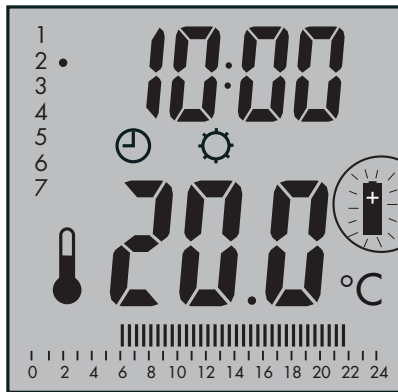
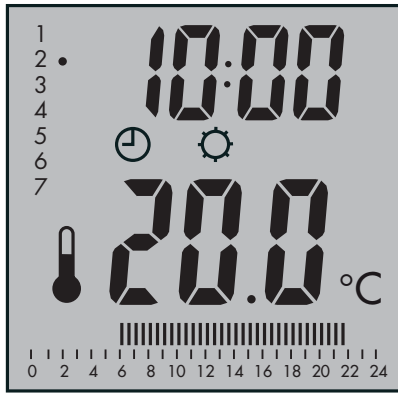

2 x AAA
LR03

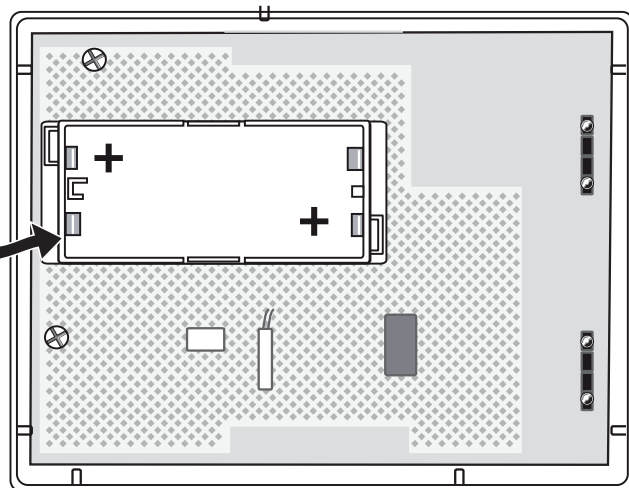

DE	Batterie ersetzen
GB	Change batteries
FR	Remplacement piles
ES	Cambio de pilas
PT	Troca de pilhas
IT	Sostituzione delle batterie
NL	Batterij vervangen
DK	Batteriskifte
PL	Wymiana baterii
HU	Elemcsere
CZ	Výměna baterie
RO	Schimbarea bateriei
SK	Výmena batérií
TR	Pil değişimi
RUS	Замена элементов питания

1



2

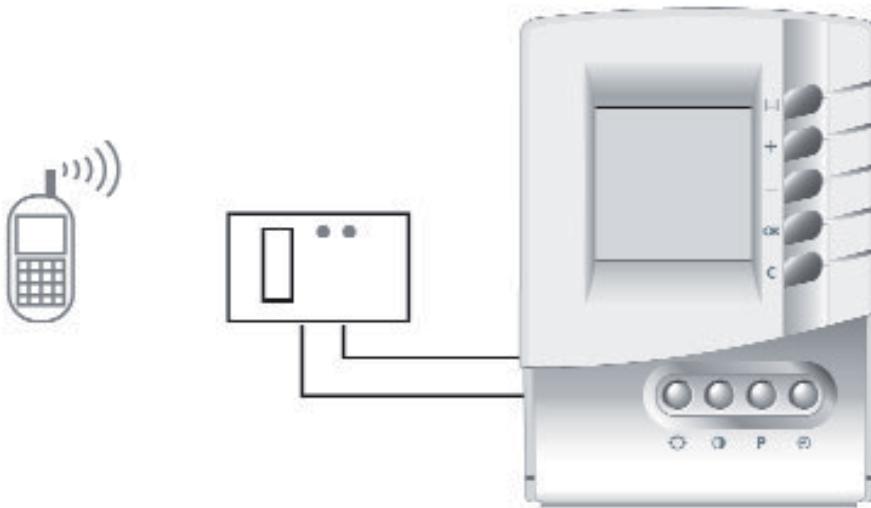

3



DE	Schalten über Telefonkontakt
GB	Connect with remote-control switch (not currently available in the UK)
FR	Enclenchement par téléphone
ES	Control telefónico a distancia
PT	Comutação mediante conexão telefónica (opcional)
IT	Inserire il comando telefonico a distanza
NL	Inschakelen op afstand via de telefoon (n.t.v. in NL)
DK	Styring via telefon
PL	Przełączenie przez telefon
HU	Telefoni átkapcsolás
CZ	Spínání pomocí telefonního kontaktu
RO	Cuplarea prin intermediul telefonului
SK	Zapnutie prostredníctvom telefonického kontaktu
TR	Telefon bağlantısıyla kumanda
RUS	Управление через телефонный контактотр

